

Read the instructions carefully and observe all safety instructions. Only carry out this installation if you are qualified to do so, otherwise we strongly recommend that you have it installed by a specialist workshop. Incorrect installation can have a negative effect on the handling of the bike and endanger your health and life. The symbols listed below are used in the following, please observe these instructions:

- ⚠ Warning! Important installation instructions. Failure to observe this warning may endanger health and life.
- ℹ Tip for installation, care or to prevent damage.

You will need the following tools:

- Torque wrench (SW3 + SW5)
- Hexagon socket SW2
- Hexagon socket SW3
- Hexagon socket SW5

We expressly recommend installing the stem only in combination with a steerer tube **[GS]** made of metal (no carbon) and without external thread. For adjustment, please remove the clamping screw **[S2]** **[Fig. 4]**. The screws **[S5]** of the handlebar covers **[LD]** must be tightened lightly by hand.

Fig.1

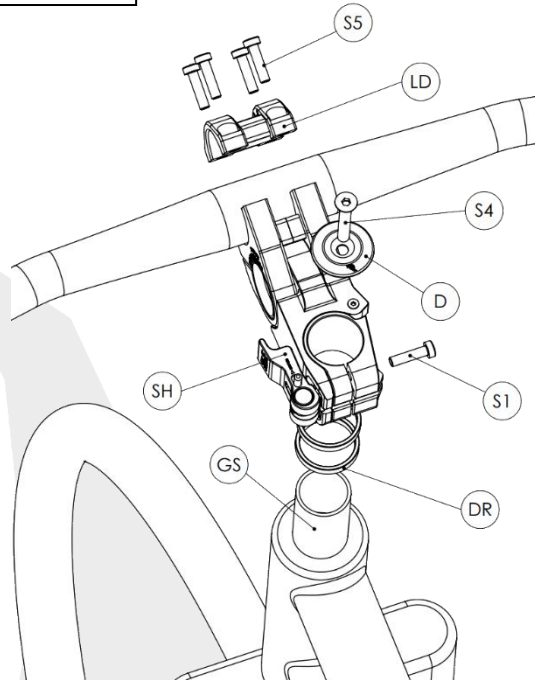
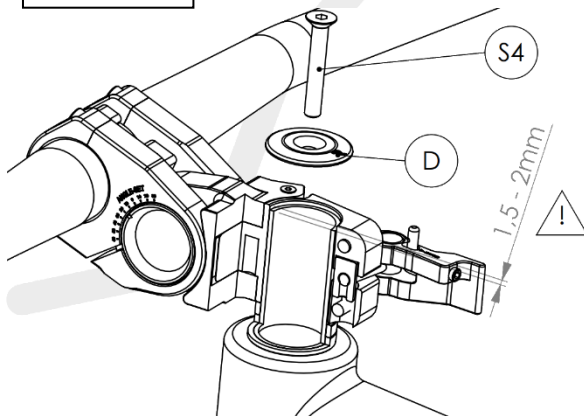
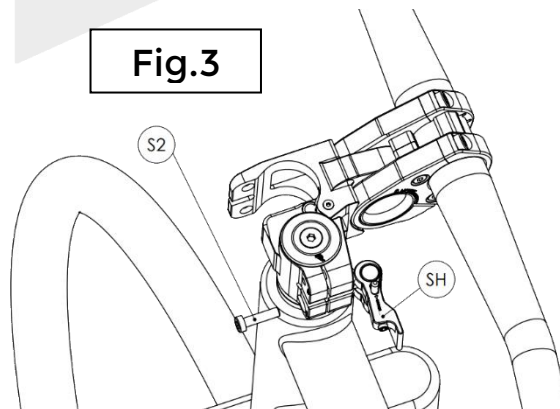

Fig.2



Align the stem using spacer rings **[DR]** (accessories, not included) so that it protrudes approx. **1.5 - 2 mm** above the steerer tube. After alignment, adjust the bearing play by tightening the **Ahead cap [D]** with the bolt **[S4]** to approx. **1.5 - 2 Nm**. Make sure that the clamping screw **[S1]** is loosened.

Fig.3



When closed (not swiveled), the stem must be aligned so that it is perpendicular to the direction of travel. First tighten the clamping screw **[S1]** hand-tight. Then open the swivel mechanism, insert the clamping screw **[S2]** and tighten the clamping screws **[S1]** and **[S2]** with a torque of **6 Nm**.

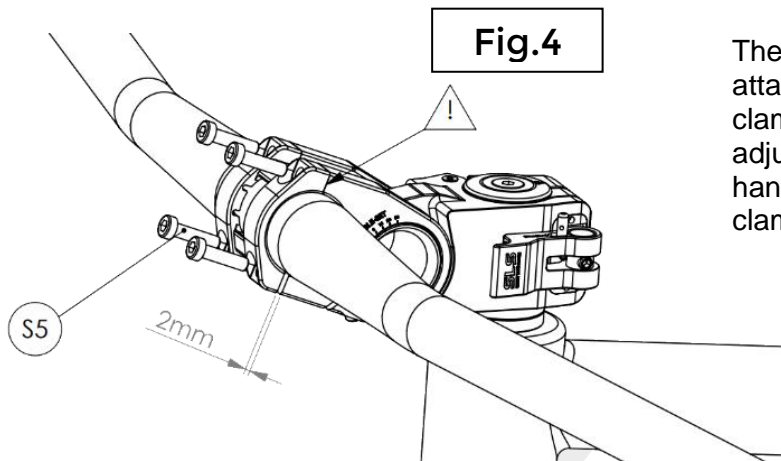

The handlebar covers must first be attached to the stem with the two upper clamping screws [S5] [Fig. 4]. Then adjust the height and angle of the handlebars [Fig. 5] by loosening the clamping screws [S3] [Fig. 5].

After aligning the height and angle of the handlebars, tighten the screws [S5] with a torque of **8 Nm** (first the top two screws, then the bottom two screws!). Tighten the clamping screws [S3] to a torque of **8 Nm**.



Attention: The S3 screws are loose when delivered. Please be sure to tighten it!

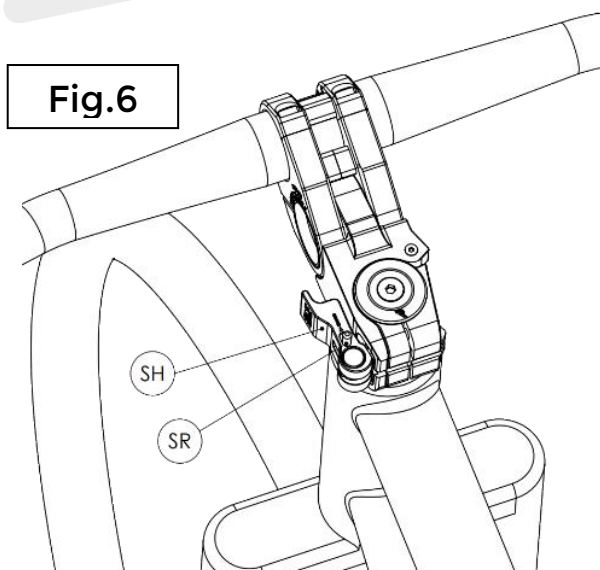
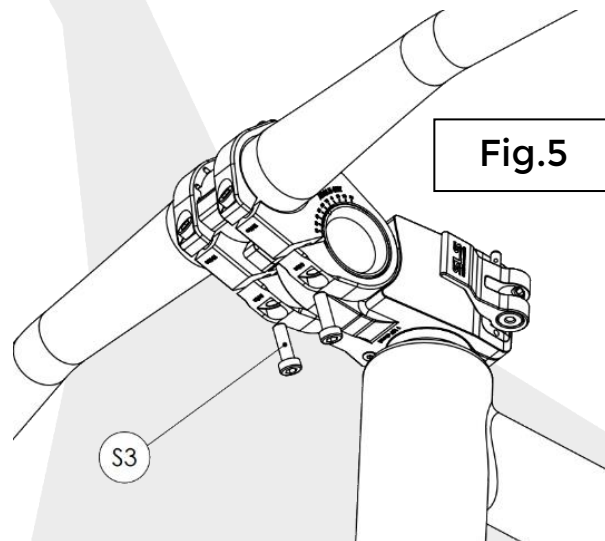

To swivel the stem, push the locking bolt [SR] forwards. Only then can the clamping lever [SH] be opened.

The stem/handlebar can now be swiveled 90° to the side. This engages in the end position. Please tighten the clamping lever [SH] in the "park position" [Fig. 7]. **Do not lift the bike by the handlebars in this position!**

Fig.7

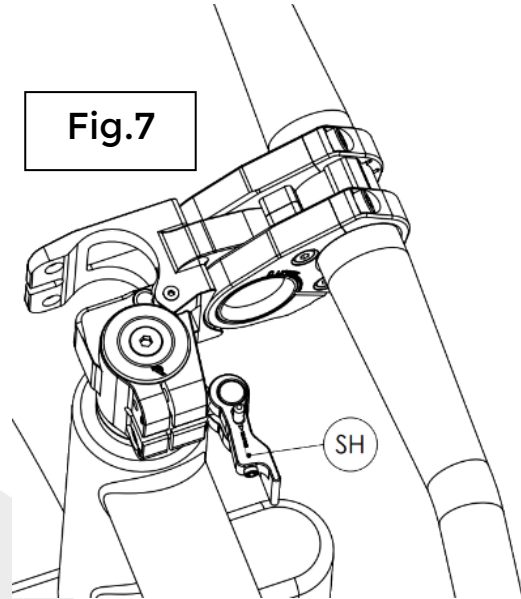
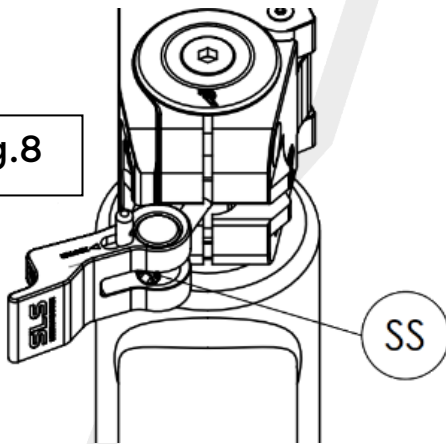

Fig.8



The clamping lever [SH] must be adjusted with the clamping screw [SS] (SW 3mm) so that locking and unlocking for the driving position is possible without great effort (two fingers).

When locking, always ensure that the locking bolt [SR] engages clearly!
The lever position must be secured with the set screw MS1 after adjustment.

If the clamping lever [SH] becomes slightly loose over time due to frequent adjustment of the pre-tensioning force [FIG.8], it can be secured again from below using the two grub screws [MS1 and MS2]. Please note that the lower clamping screw [S2] must be removed for this and tightened again with a torque of **6 Nm** after screwing it in.

MS₂

Fig.9

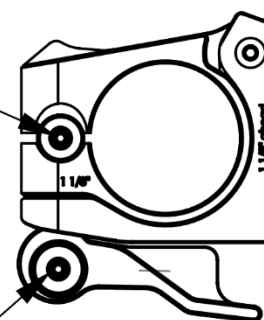
MS₁

**General safety instructions:**

- Make sure that cables, wires and hoses are routed tension-free over the entire steering angle and are not kinked.
- Do not mount any attachments such as child seats or luggage racks on the stem/handlebars. An impermissible load could damage the stem.
- The screw connections must be tightened to their tightening torques 50 km after initial installation and at every maintenance or once a year (at least every 1,000 km).
- Our stems are designed for everyday use on bicycles, MTBs and e-bikes. Usage such as downhill, dual slalom, jumps, freeride or similar is excluded.
- We recommend a handlebar width of 680 mm and a rider weight (with luggage) of 100 kg.

