

Read the instructions carefully and observe all safety instructions. Only carry out this assembly if you are qualified to do so, otherwise we strongly recommend assembly in a specialist workshop. Incorrect attachment can negatively affect the handling of the bike and endanger your health and life. The symbols listed below are used in the following, please note these instructions:

- ⚠ Warning! Important mounting note. Failure to do so may endanger health and life.
- 📌 Tips for mounting, care or to avoid damage.

You need the following tools:

- Torque wrench (SW3 + SW5)
- Hexagon socket SW2
- Hexagon socket SW3
- Hexagon socket SW5

We expressly recommend installing the stem exclusively in combination with a steerer tube **[GS]** made of metal (not carbon) and without an external thread. To adjust, please remove the clamping screw **[S2]**. The screws **[S4]** of the handlebar covers **[LD]** should be easily tightened by hand.

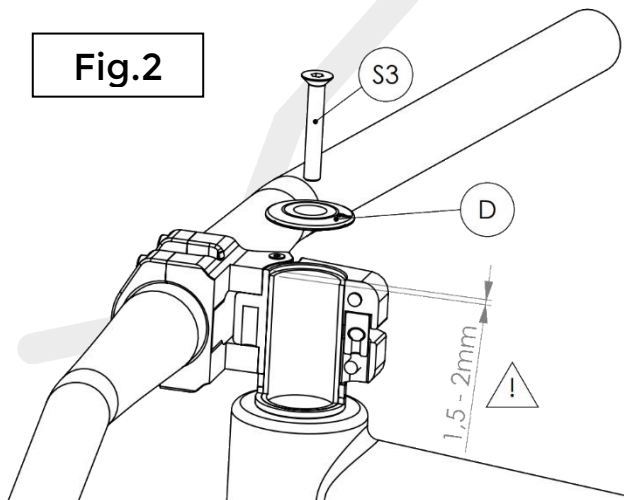
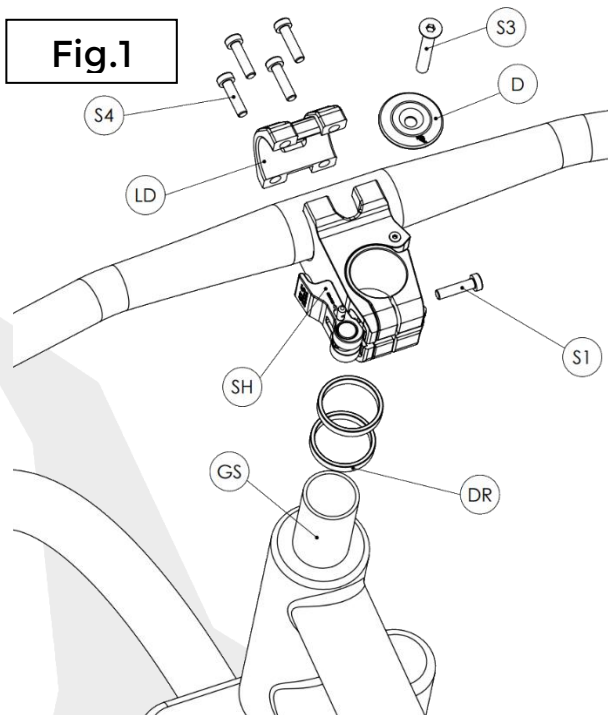

The stem must be aligned using spacer rings **[DR]** (accessory, not included) so that it protrudes approx. 1.5 - 2 mm above the fork shaft. After aligning, adjust the bearing play by tightening the ahead cover **[D]** with the screw **[S3]** with approx. **1.5 - 2 Nm**. Make sure that the clamping screw **[S1]** is loose.

When closed (not swiveled), the stem must be aligned so that it is transverse to the direction of travel. First tighten the clamping screw **[S1]** hand-tight. Then open the swivel mechanism, insert the clamping screw **[S2]** and tighten the clamping screws **[S1]** and **[S2]** with a torque of **6Nm**.

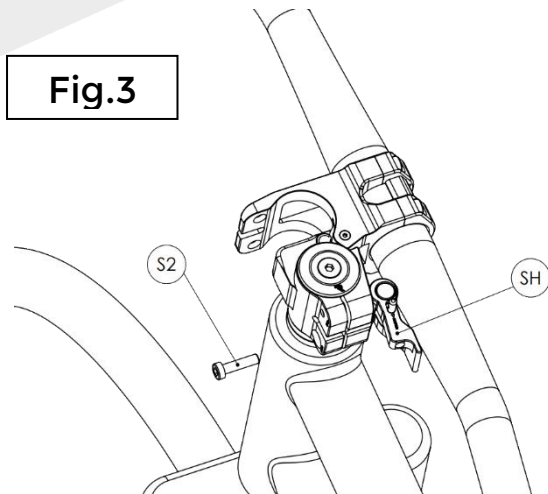

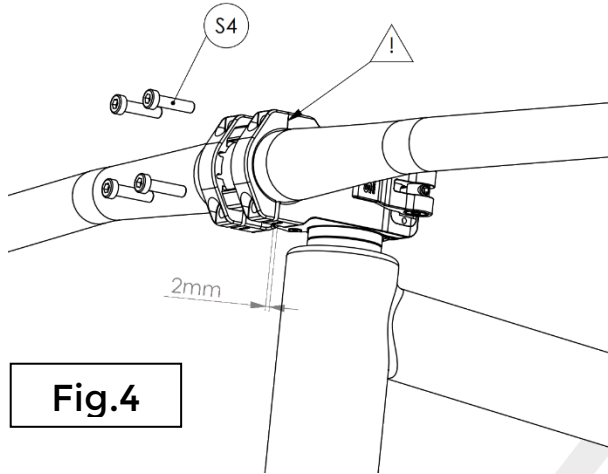

The handlebar covers must be attached to the stem using the top two clamping screws [S4] [Fig. 4]. After aligning the handlebars in height and inclination, tighten the screws [S4] [Fig.4] with a torque of **6-8Nm** (first the top two screws, then the bottom two screws!).

To swivel the stem, the locking bar [SR] must be pushed forward. Only then can the tensioning lever [SH] be opened.

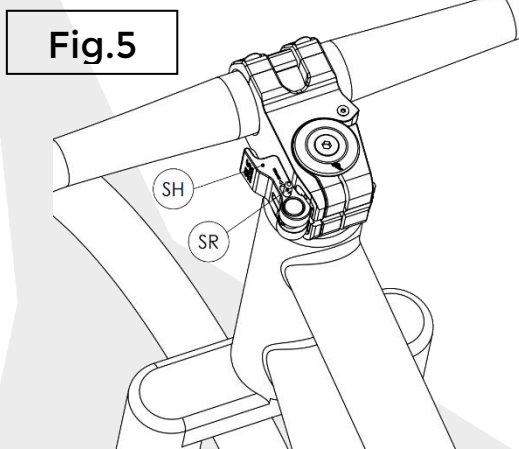
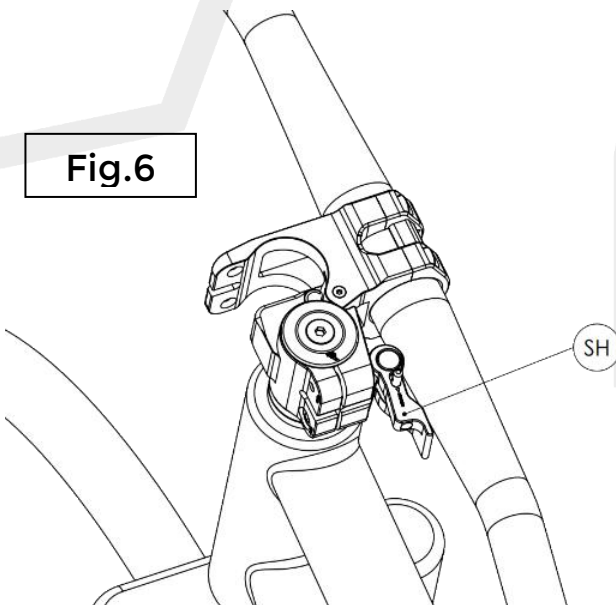

Fig.6



The stem/handlebar can now be swiveled 90° to the side. This locks into the end position. In this position, please do not lift the bike by the handlebars!

The tensioning lever [SH] must be adjusted using the tensioning screw [SS] (SW 3mm) so that locking and unlocking for the driving position is possible without great effort (two fingers).

When locking, always make sure that the locking latch [SR] clicks into place clearly!

After adjustment, the lever position must be secured with the grub screw MS.

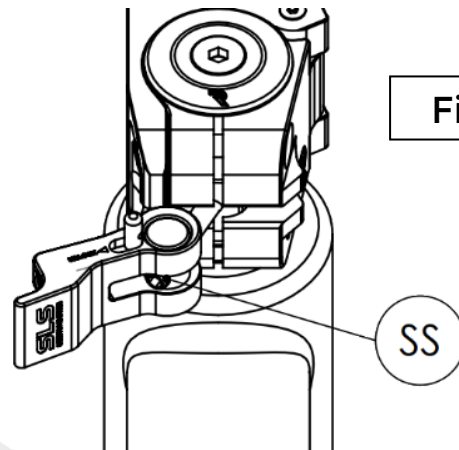

Fig.7

If the tensioning lever [SH] becomes loose over time due to frequent use, it is possible to secure it against twisting again.

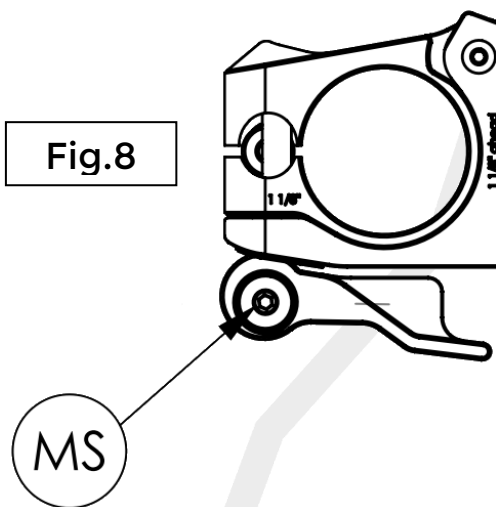

Fig.8

Please loosen the grub screw [MS] in the clamping lever and the counter screw [KS]. Now the clamping screw [SS] can be readjusted slightly (see description in FIG. 7). Now the grub screw and the counter screw must be tightened hand-tight again.

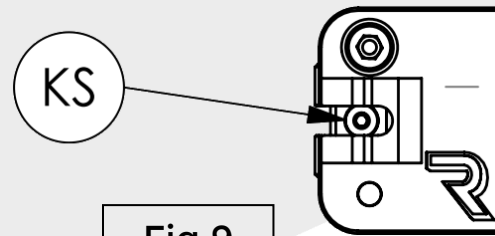

Fig.9



General safety instructions:

- Make sure that cables, cables and hoses are laid without tension over the entire steering angle and are not kinked.
- Do not mount attachments such as child seats or luggage racks on the stem/handlebars. An impermissible load could lead to damage to the stem.
- Do not lift the bicycle/e-bike on the handlebars when it is swung out or secure it for transport.
- The screw connections must be tightened to their tightening torques 50 km after initial installation and during every maintenance or once a year (at least every 1,000 km).
- Our stems are designed for everyday use on bicycles, MTBs and e-bikes. Downhill, dual slalom, jumps, freeride or similar is excluded.
- We recommend a handlebar width of 680 mm and a rider weight (with luggage) of 100 kg.